

SECTION I INTRODUCTION

1.1 GENERAL INFORMATION

This manual is intended to assist users in the installation, operation, and maintenance of the PHI Model 10-420 Toroidal Monochromator. The manual is divided into five sections. Section I contains a brief description and specifications of the unit. Section II refers to checkout procedures and installation. Section III describes the operation of the toroidal monochromator, while Section IV explains the theory of operation. Calibration and maintenance are discussed in Section V.

1.2 GENERAL DESCRIPTION

The PHI Model 10-420 Toroidal Monochromator is designed to be used on the PHI 5500/5600 Multi-Technique Systems and consists of a crystal assembly, a crystal manipulator and the monochromator housing. The monochromator housing contains two flanges for mounting onto the test chamber and the x-ray source. Mounting on test chambers of other systems can also be done, if they have a 6.95 inch port length and adequate clearance conditions.

The toroidal monochromator's crystal assembly and crystal manipulator are both mounted in the monochromator housing. The crystal assembly is composed of a set of precisely oriented quartz crystals. This set of crystals is aligned by the crystal manipulator, to produce a monochromated x-ray beam. The manipulator has three separate motions for crystal alignment: translation and two directions of tilt. A shutter is provided on the

monochromator housing to shield the crystal assembly and monochromator during sputtering.

The monochromator provides the following advantages over the standard dual-anode x-ray source: improved energy resolution, lower spectral backgrounds, the absence of certain satellites and "ghost" peaks, and reduced sample damage.

1.3 SYSTEM CONFIGURATION

Figure 1-1 shows how the toroidal monochromator package interfaces with the analytical system. The package consists of the PHI Model 10-600 X-Ray Source, an x-ray source aligner which connects the x-ray source to the monochromator, and associated cables and water lines. The toroidal monochromator bolts to, and is supported by, a six inch flange on the bell jar. If the system configuration includes a standard PHI Model 04-548 X-Ray Source, the PHI Model 20-040 High Voltage Supply is wired to both sources, and switching between the two sources is controlled either manually or by the computer through the PHI Model 32-096 X-Ray Source Control. Anode cooling is provided by the standard PHI Model 16-050 Heat Exchanger with the two sources plumbed in series.

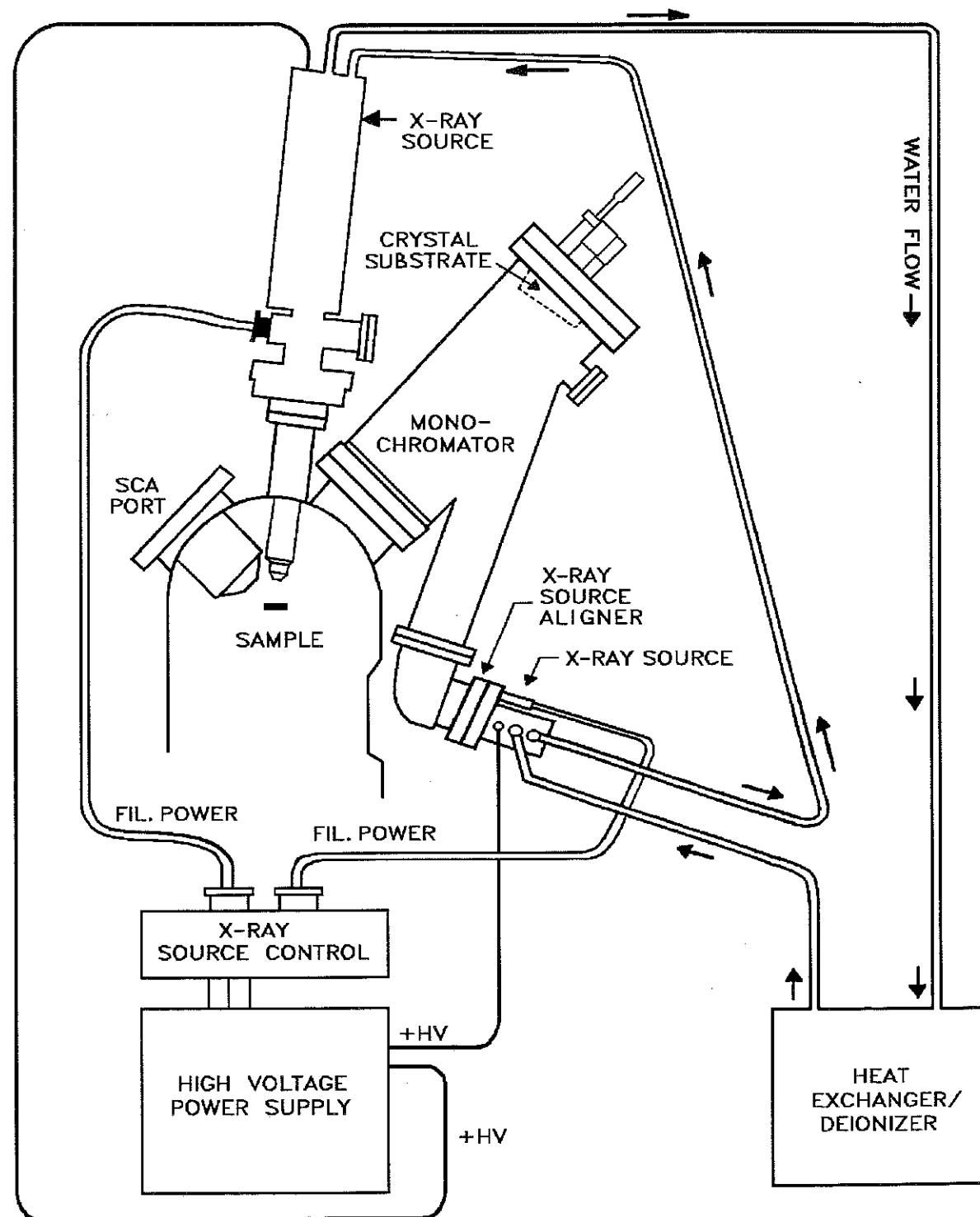

Figure 1-1. PHI Model 10-420 Toroidal Monochromator Package/System Interface.

1.4 SYSTEM SPECIFICATIONS

1.4.1 Count Rates and Resolution

*Omni Focus II Lens in high solid angle mode**

The Al monochromator operating at 14 kV on a smooth, sputter-cleaned sample of silver (Ag 3d_{5/2} peak) will meet or exceed the curve defined by the following performance specifications for a 1.1 mm dia. analysis area:

Anode Power	Detector	Resolution FWHM (eV)	Sensitivity cps
400 W	PSD	≤ 0.50	50,000
400 W	PSD	≤ 0.60	120,000
400 W	SCD	≤ 0.50	18,000
400 W	SCD	≤ 0.60	40,000

*Omni Focus III Lens in high solid angle mode**

The Al monochromator operating at 14 kV on a smooth, sputter-cleaned sample of silver (Ag 3d_{5/2} peak) will meet or exceed the curve defined by the following performance specifications for a 800 μm dia. analysis area:

Anode Power	Detector	Resolution FWHM (eV)	Sensitivity cps
400 W	MCD	≤ 0.51	125,000
400 W	MCD	≤ 0.60	300,000

*Hardware configuration:

- PHI Model 10-420 Toroidal Monochromator
- PHI Model 10-600 Monochromator X-ray Source
- Omni Focus II Small Area Lens or Omni Focus III Small Area Lens with MCD
- PHI Model 10-360 Precision Energy Analyzer (SCA)

1.4.2 Optics Adjustments

The monochromator has the following adjustments for optical alignment:

X-Ray Anode:	X Y Z
Monochromator Crystal:	X- Tilt Y- Tilt Focus.

1.4.3 Vacuum Performance

Monochromator Bakeout Temperature:	150°C (controlled by thermostat on 10-420).
Base Pressure:	<5 x 10 ⁻¹⁰ Torr.

1.4.4 Other

Power:	400 W (14 kV, 28.6 mA) recommended continuous power in point mode. 600 W (15 kV, 40 mA) recommended continuous power in area mode.
Maximum Anode Power:	600 watts.
Room Temperature:	20°C ± 5° C.

SECTION II INITIAL CHECKOUT AND INSTALLATION

2.1 GENERAL INFORMATION

The housing and crystals for the PHI Model 10-420 Toroidal Monochromator are shipped separately. Installation is required for the unit and must be performed by PHI service personnel.

Visual inspection of the system is required to insure that no damage occurred during shipping. If damage did occur, contact the freight company immediately.

CAUTION

DO NOT REMOVE THE BLANKETS ON ANY SYSTEM EQUIPPED WITH A MONOCHROMATOR UNTIL THE SYSTEM HAS THOROUGHLY COOLED. RAPID THERMAL CHANGES CAN DAMAGE THE CRYSTALS LOCATED WITHIN THE MONOCHROMATOR.

SECTION III OPERATION

3.1 GENERAL INFORMATION

This section contains information on using the toroidal monochromator. Various x-ray source preliminary operating procedures are required whenever a new x-ray source or filament has been installed, when the x-ray source has been exposed to air or when the x-ray source has not been operated for several months. Refer to Section III of the PHI Model 10-600 X-Ray Source manual for detailed procedures.

3.2 ALIGNMENT UNDER VACUUM

The toroidal monochromator has six adjustments. Three adjustments are located on the top of the monochromator housing: the x-tilt, y-tilt and focus. They are used to position the crystal assembly. The other three adjustments are on the x-ray source aligner. They are used to position the x-ray source.

1. Perform the microscope calibration procedure before aligning the monochromator. (Refer to Section 4 of the Installation, Calibration and Maintenance manual for your system.)
2. Introduce a clean, flat sample into the system. The sample consists of a flat silver sample mounted on a phosphor screen (Part No. 618646). The screen is then attached to a sample mount. See Figure 3-1 below.

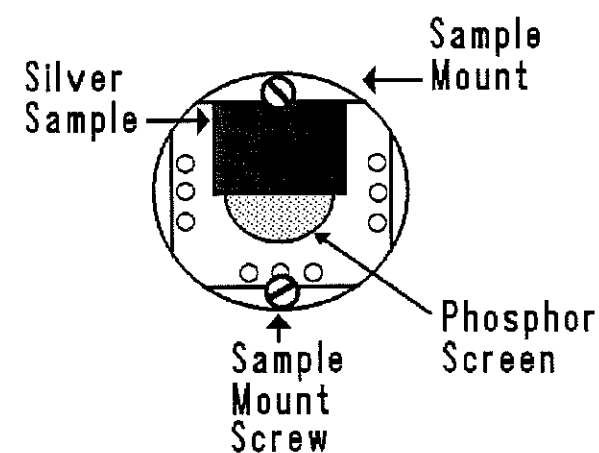

Figure 3 - 1. Silver sample on phosphor screen.

3. Using the Al side of the Model 04-548 Dual Anode X-ray Source, scan the Ag $3d_{5/2}$ peak at 368 eV binding energy to determine the exact location of the peak maximum. Use a pass energy near 20 eV and the largest lens aperture. The peak should be slightly asymmetric, with the maximum occurring just to the right of peak center. Note the binding energy of the peak.
4. Switch from the dual anode to the monochromatic x-ray source. Ensure that the monochromator shutter is open.
5. Set the crystal focus to the last recorded setting. If the monochromator is far out of alignment, move the phosphor screen into the analysis position. The phosphor screen side of the sample mount is used because it is easiest to find the x-ray beam with phosphor.

The beam appears on the phosphor screen sample surface as a bright blue spot. Starting with the crystal Y tilt, crystal X tilt, source Y and Source X adjustments, adjust the monochromator until a blue light appears on the phosphor screen. The blue light is produced by fluorescence from Al $K\alpha$ x-ray excitation. The yellow-orange light occurring near the blue light is reflected light from the filament.

NOTE:

If the x-ray source has been serviced prior to the start of this procedure, then the Source Y adjustment should only be necessary if the other adjustments have not been moved.

6. When the spot is located, use the x-ray source aligner and y-tilt to center the blue light in the y-direction and to maximize its intensity. Use the x-tilt to center it in the x-direction. Refer to Table 3-1.

Use the focus adjust and the y-tilt to obtain the sharpest and brightest image possible. Repeat step 5 to recenter the light, if necessary. Reposition the sample stage so that the silver specimen and not the phosphor screen is at the focal point.

- 7.

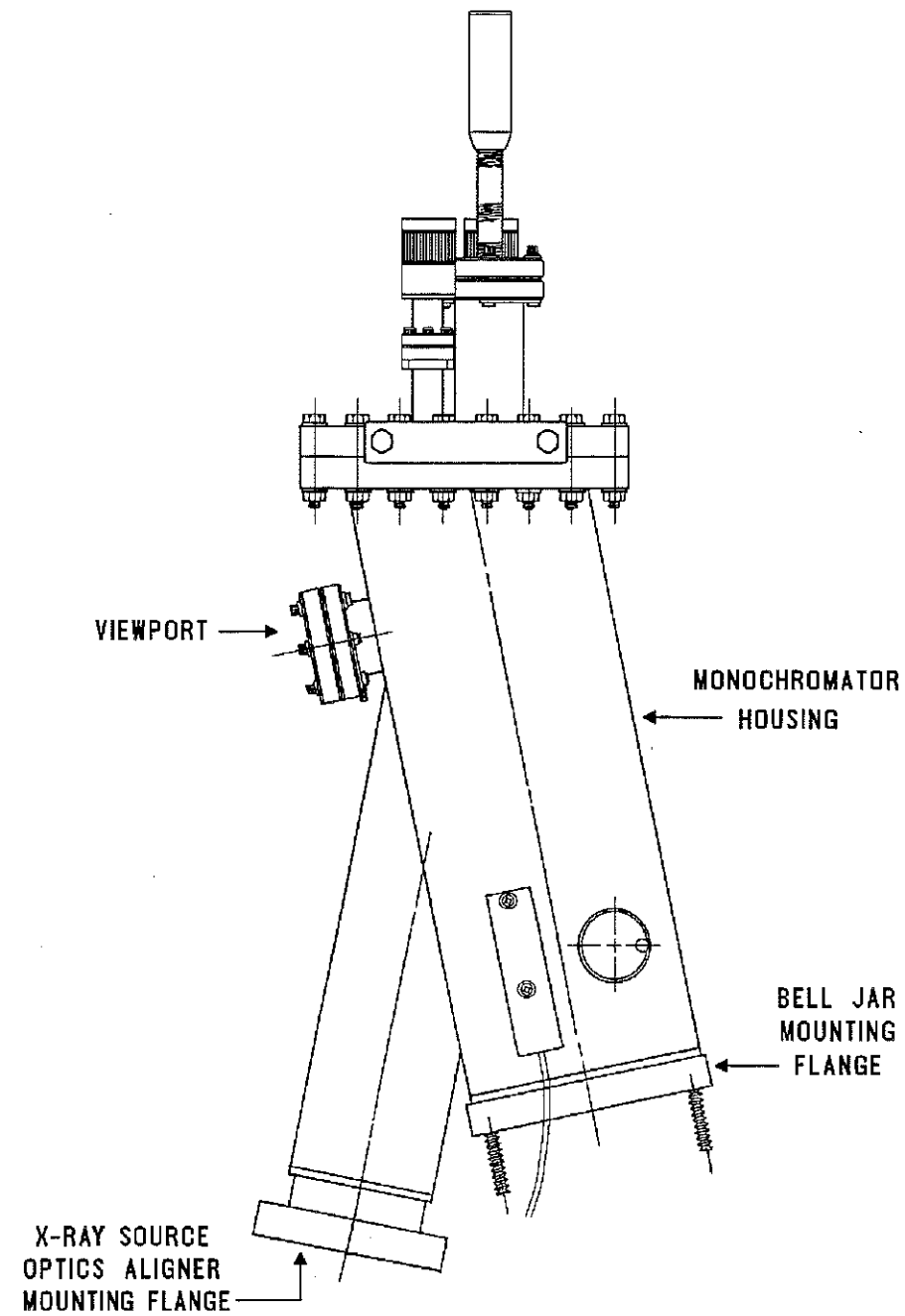

Figure 3 - 2. Side View of the PHI Model 10-420 Toroidal Monochromator.

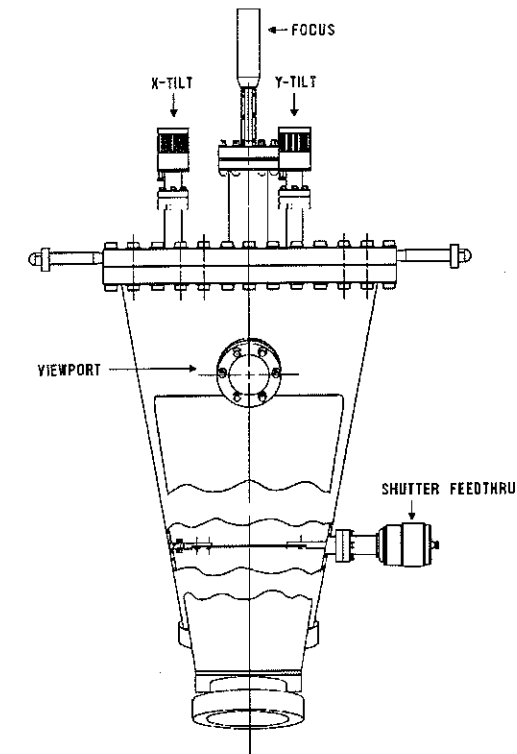

Figure 3 - 3. Front View of the Model 10-420 Toroidal Monochromator.

8. Select the **[Setup Align]** software command to display the ESCA Alignment Menu and set up a narrow window acquisition range around the 368 eV line (Ag 3d_{5/2} peak). Using the same pass energy, work function and lens aperture as in step 3, and perform the **[Refresh Acquire]** acquisition process.
9. Align the x-ray beam (that is, move it in the y-direction) by adjusting the monochromator Y-tilt and the source - Y to maximize the target current. The Y-tilt and source - Y must be moved simultaneously for this adjustment. When the x-ray beam is properly aligned, the count rate and target current should be maximized, and the peak energy should have the same value as in step 3.
10. Align the monochromator by adjusting the monochromator x-tilt to maximize the count rate. When the monochromator is properly aligned, the target current is typically 1-2 nA.
11. Acquire the Ag 3d_{5/2} spectrum and determine the peak's full width at half maximum (FWHM) and count rate.
12. Adjust the monochromator crystal by rotating the focus adjust knob one full revolution. Repeat steps 8 through 11.
13. Repeat step 12, making adjustments in both directions until the focus position giving the smallest FWHM is found.
14. Tilt the silver sample to 65-70°. Adjust the stage y-axis to maximize signal. The count rate should increase by approximately 50% at this tilt angle, and resolution should improve.

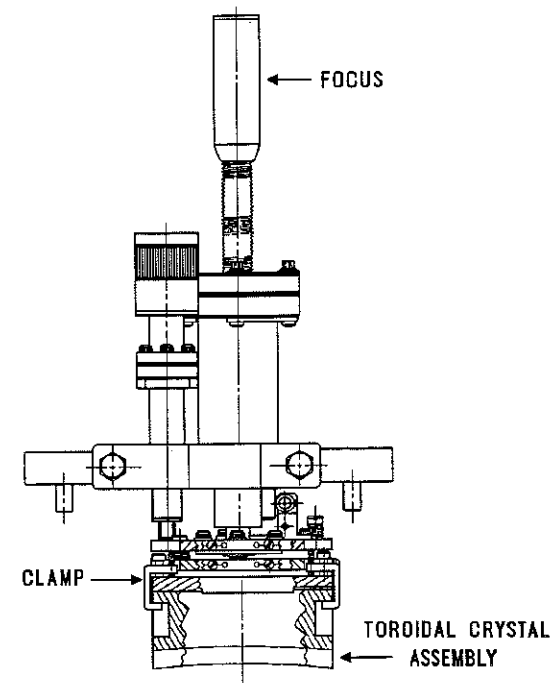
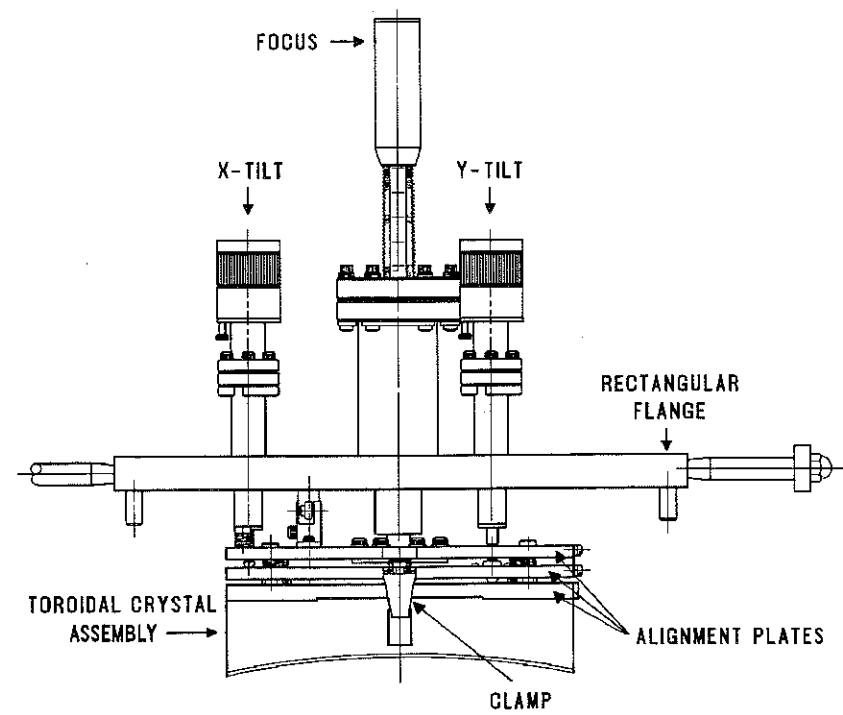

Figure 3 - 4. Toroidal Crystal Assembly and Manipulator.

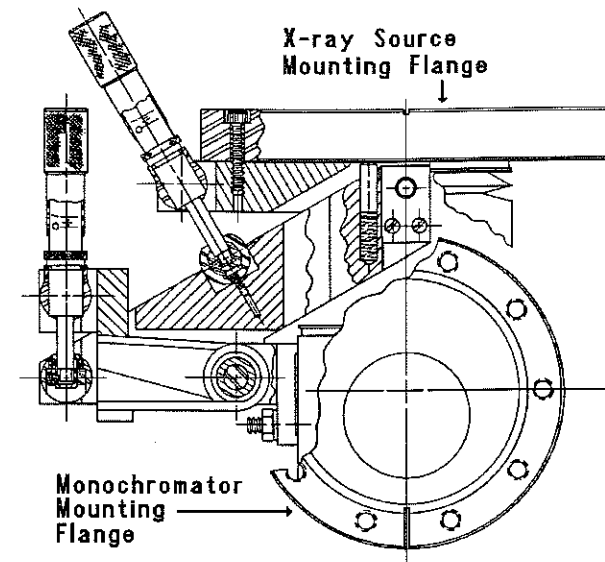

Figure 3 - 5. Top view of x-ray source aligner.

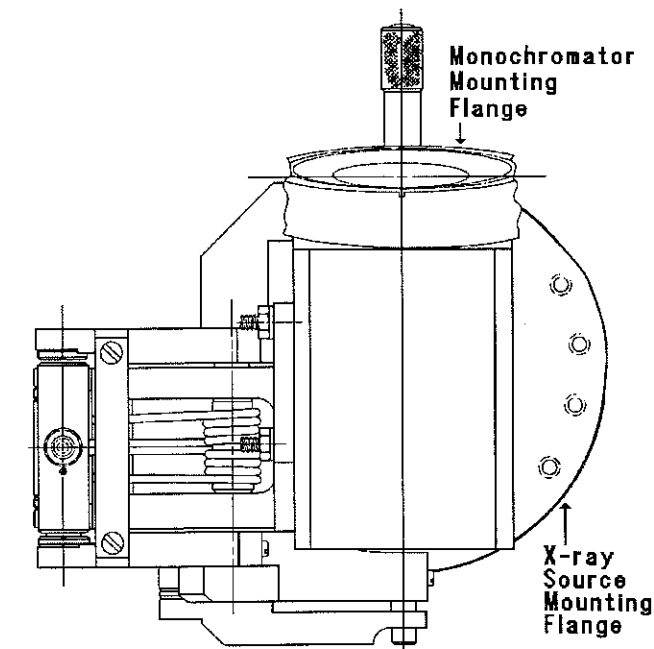

Figure 3 - 7. Rear view of x-ray source aligner.

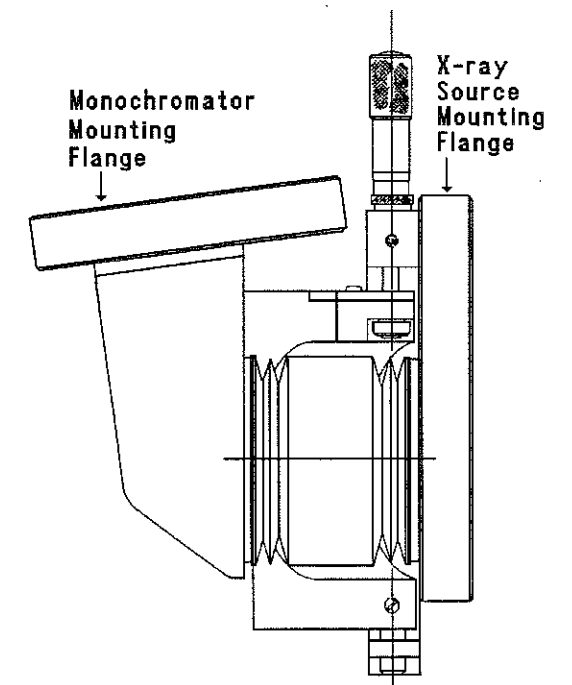

Figure 3 - 6. Left side view of x-ray source aligner.

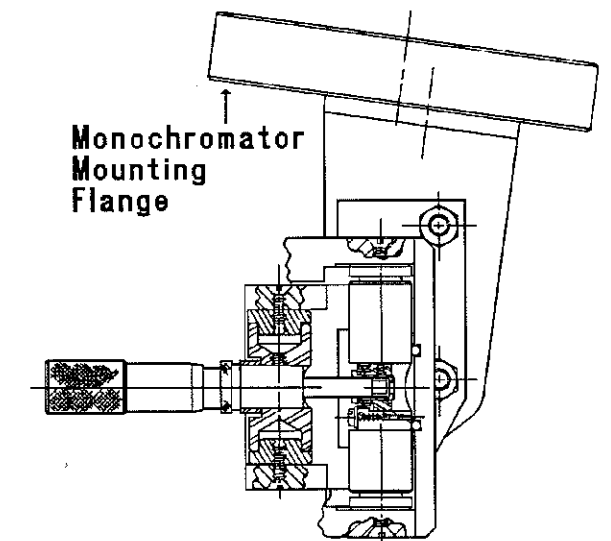

Figure 3 - 8. Right side view of x-ray source aligner.

- When the monochromator has been aligned, lock all adjustments into position with the appropriate locking screws and nuts. Subsequent analyses require adjusting only sample position and tilt for maximum count rate. Record all settings for future reference.

NOTE

When the monochromator is not being used, ensure that the shutter is closed.

3.3

SELECTION OF MONOCHROMATOR SOURCE

With the system configured as in Figure 1-1, either the monochromated x-ray source or the standard x-ray source can be used in sample analysis. To use monochromated x-rays, first set the Model 32-096 X-ray Source Control to EXTERNAL. In the PHI software, enter the Hardware Configuration Menu and set the monochromated x-ray source parameter to YES. Next, enter the X-ray Menu. Specify Al for the anode material and 400 watts maximum for the anode power.

Table 3 - 1
Summary of 10-420 Monochromator Alignment with 10-600 X-ray Source

Adjustment	Phosphor Sample	Silver Sample in Align Mode
Crystal y-Tilt	Position beam in y-direction	Set correct peak energy. (Interacts with Source y).
Source y	Maximize brightness	Maximize photocurrent. (Interacts with Crystal y-Tilt).
Crystal x-Tilt	Coarse beam position in x-direction	
Source x		Fine x beam position. Use to maximize signal.
Source z	Sharpest visual focus.	
Sample Tilt	Set sample horizontal, if using microscope, or tilt toward viewport.	Set to approx. 65° for maximum signal.
Sample x	Move to phosphor half of sample.	Move to silver half of sample.
Sample y		Maximize signal on tilted sample.
Crystal focus	Perform all of the above at a single crystal focus setting. Vary the crystal focus to optimize resolution.	

NOTE

Only select the monochromated x-ray source parameter in the Hardware Configuration Menu for collecting data while using the monochromator. Choosing this parameter changes the sensitivity factors used in the quantification of data.

Table 3 - 2. Toroidal Monochromator Specifications for SCD or PSD*

Analysis Area	Resolution FWHM(eV)	Sensitivity SCD (cps)	Sensitivity PSD (cps)
1.0 x 3.5 mm slit	≤0.52	25,000	75,000
1.0 x 3.5 mm slit	≤0.60	50,000	150,000
1.0 mm dia.	≤ 0.50	18,000	50,000
1.0 mm dia.	≤ 0.60	40,000	120,000
0.6 mm dia.	≤ 0.50	10,000	30,000
0.6 mm dia.	≤ 0.60	20,000	60,000
0.2 mm dia.	≤ 0.50	1,000	3,000
0.2 mm dia.	≤ 0.60	2,500	7,500

***Hardware configuration:**

- PHI Model 10-420 Toroidal Monochromator
- PHI Model 10-600 Monochromatic X-ray Source (operating at 400 Watts)
- Omni Focus™ II Small Area Lens
- PHI Model 72-360 Small Area Lens Bias Board (in small area mode)
- PHI Model 80-360 Digital Hemispherical Analyzer Control
- PHI Model 10-360 Precision Energy Analyzer (SCA)

3.4 RUNNING SPECIFICATIONS

- When all adjustments have been optimized as described previously, obtain a series of Ag 3d_{5/2} spectra over the range 370-366 eV at pass energies 4.45, 8.92, 17.90, 35.75, and 71.55 eV.
- Draw baselines from the background at 370 to the background at 366 and determine the FWHMs.
- Plot FWHM vs counts/second on semilog graph paper and draw a smooth curve through the points. The curve should meet or exceed the values shown in Table 3-2 and Table 3-3.

Table 3 - 3. Toroidal Monochromator Specifications for MCD*

Analysis Area	Resolution FWHM(eV)	Sensitivity MCD (cps)
0.8 x 2 mm slit	≤0.52	150,000
0.8 x 2 mm slit	≤0.60	450,000
0.8 x 2 mm slit	≤1.00	1,750,000
800 μm dia.	≤ 0.51	125,000
800 μm dia.	≤ 0.60	300,000
800 μm dia.	≤ 1.00	1,000,000
400 μm dia.	≤ 0.50	75,000
400 μm dia.	≤ 0.60	200,000
400 μm dia.	≤ 1.00	575,000
150 μm dia.	≤ 0.50	7,500
150 μm dia.	≤ 0.60	20,000
150 μm dia.	≤ 1.00	50,000

***Hardware configuration:**

- PHI Model 10-420 Toroidal Monochromator
- PHI Model 10-600 Monochromatic X-ray Source (operating at 400 Watts)
- Omni Focus™ III Small Area Lens with MCD
- PHI Model 72-366 Small Area Lens Bias Board (in minimum area mode)
- PHI Model 80-365/A or 80-366/A Digital Hemispherical Analyzer Control
- PHI Model 10-360 Precision Energy Analyzer (SCA)

3.5 EXAMPLES OF OPERATION

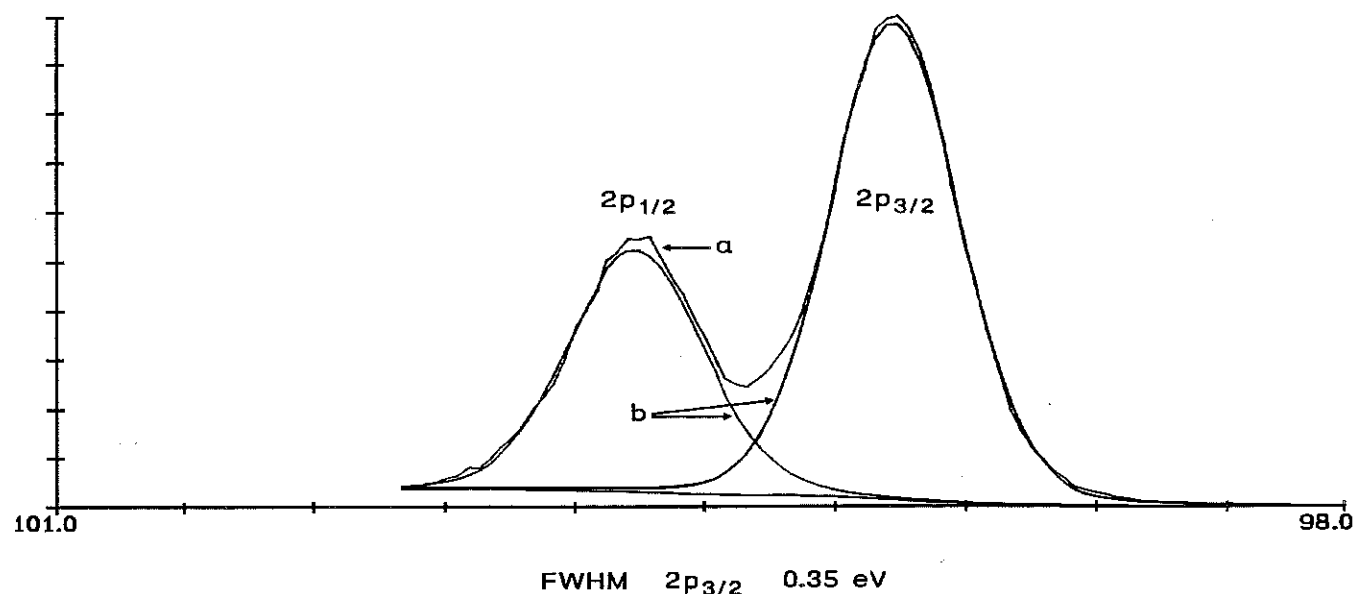

Figure 3 - 9. Data acquired on a Si wafer with the monochromator using a 1.1 mm dia. aperture and PSD detector. This Si 2p spectrum shows several advantages of the monochromator. Line a shows the raw data. Without the monochromator, the Si 2p doublet would appear as a single peak. Line b shows a curve fit of the raw data by two peaks.

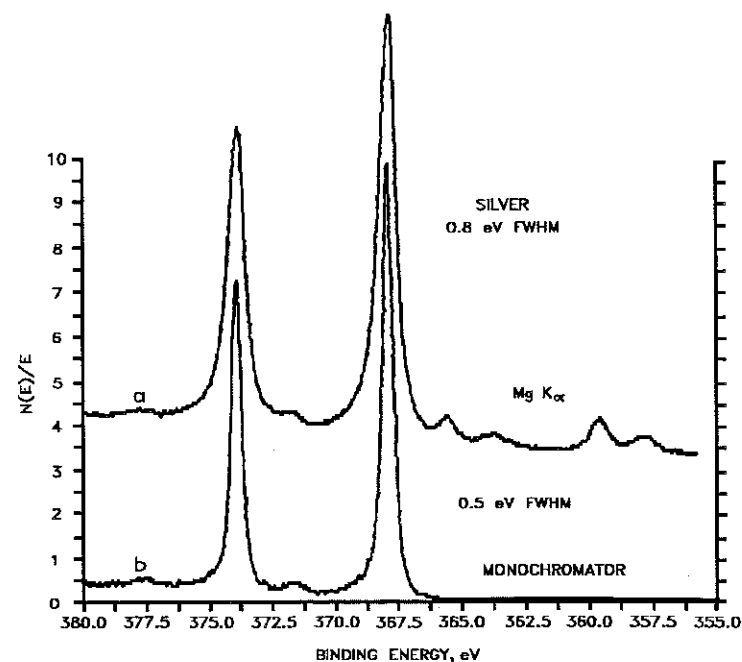

Figure 3 - 10. Data acquired from a silver sample using both a standard x-ray source (a) and the monochromator (b). Use of the monochromator results in narrower peaks (0.50 eV line width), the disappearance of satellite peaks, and a decrease in background.

SECTION IV
THEORY OF OPERATION

4.1 GENERAL INFORMATION

The PHI Model 10-420 Toroidal Monochromator provides an intense x-ray flux with monochromatic x-ray energy distribution and is based on a 500 mm Rowland circle geometry for high x-ray energy dispersion. This x-ray energy dispersion eliminates the $K\alpha_{3,4}$, $K\alpha_{5,6}$, and $K\beta$ x-ray lines and the Al Bremsstrahlung radiatio background and narrows the Al $K\alpha_{1,2}$ line to approximately 0.2 eV FWHM. This narrow line allows core and valence band spectra to be acquired with high energy resolution of the photoemission peaks and without x-ray satellite-induced photoemission peak overlaps.

The removal of x-ray and Bremsstrahlung satellite radiation coupled with a narrower principle excitation line width results in significantly higher signal-to-background ratio data. The narrower x-ray linewidth also allows an electron energy analyzer to be operated with higher transmission, thereby reducing the observed damage rate in monochromator-excited XPS spectra of x-ray sensitive samples.

The quartz crystals contained in the toroidal monochromator, used for x-ray diffraction, are mounted in a Rowland circle geometry using a toroidal crystal surface. The large surface area of the quartz crystals define a large solid angle for x-ray diffraction and hence lead to an intense x-ray flux from the monochromator.

The toroidal monochromator operates according to Bragg's Law for x-ray diffraction. A single wavelength of $K\alpha$ x-radiation from a conventional aluminum anode is reflected from a (100) quartz crystal surface at a specific angle of reflection (Bragg's law). With the proper geometric configuration of the x-ray source, crystal substrate and analysis target, the reflected beam yields a highly focused, monochromatic source of x-rays.

X-RAY DIFFRACTION

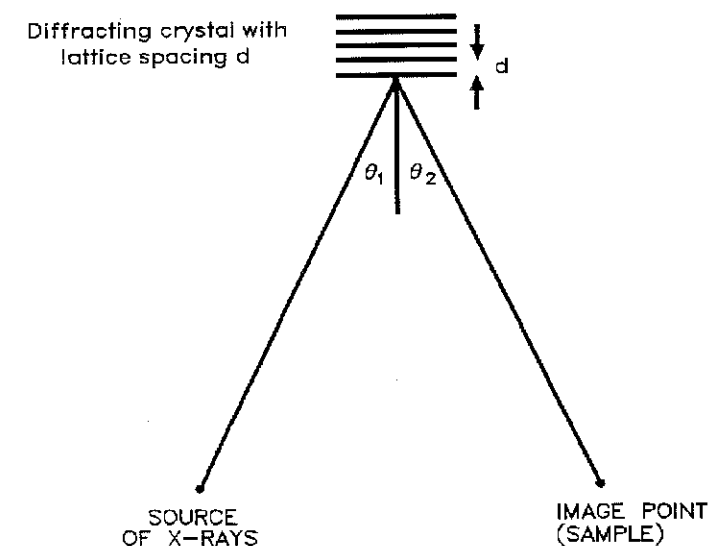

CONDITIONS FOR X-RAY DIFFRACTION:

1. $\theta_1 = \theta_2$
2. $\lambda = 2d \cos \theta$ Bragg's Law

Figure 4-1. Principles of x-ray diffraction.

Section IV - Theory of Operation

4.2 X-RAY DIFFRACTION

Figure 4-1 illustrates the reflection of x-rays from the crystal and the necessary conditions for x-ray diffraction. In the specific case of Al $K\alpha$ radiation diffracted by a quartz (100) crystal,

$$\begin{aligned}\lambda &= 8.34 \text{ \AA}, \\ d &= 4.255 \text{ \AA}, \\ \theta &= 11.5^\circ.\end{aligned}$$

4.3 OPTICS CONFIGURATION

Figure 4-2 shows the optics configuration of the toroidal monochromator. The x-ray source, crystal substrate and

analysis target are located in a specific geometry around 500 mm diameter Rowland circle. The radiation is taken from the anode at a grazing angle so that it appears to form a line source. The quartz crystal is bent to a 500 mm radius with its center tangent to the Rowland circle. The reflected x-rays form an angle of 23° with the incident radiation. The input lens of the analyzer is at 90° with respect to the monochromatic x-radiation.

There are several adjustments provided for optical alignment. The x-ray source aligner enables the user to position the anode on the Rowland circle. The crystal substrate assembly can be tilted in two directions and moved in the z (focus) direction with respect to the test chamber in order to place the sample on the Rowland circle.

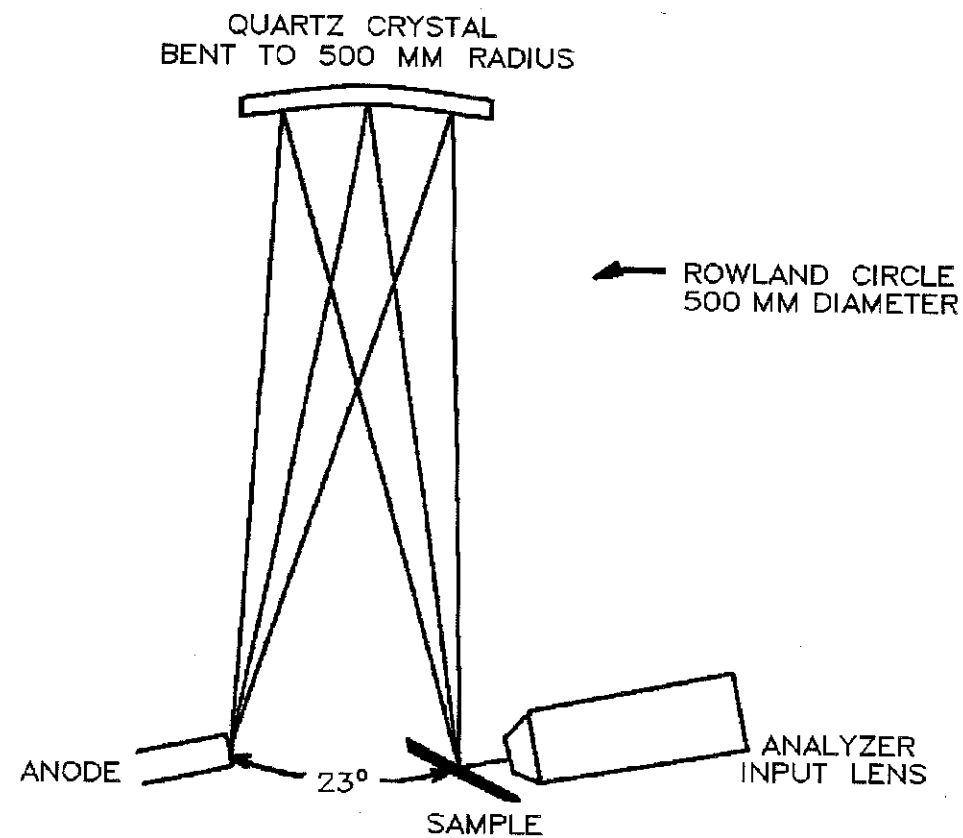

Figure 4-2. Toroidal Monochromator Optics Configuration.

SECTION V CALIBRATION AND MAINTENANCE

5.1 GENERAL INFORMATION

Refer to the system manual for complete system calibration. There are no calibration procedures, other than the alignment described in Section III, and no maintenance procedures for the toroidal monochromator.

If the PHI Model 10-420 Toroidal Monochromator fails to perform specified functions, contact the PHI Customer Service Department.